

Magnetic Lock

MG-250FM

ASSA ABLOY MG-250FM Flush Mounted Monitoring Magnetic Lock

Features

- Suitable for aluminium, wooden and iron door
- Designed for flush mount applications
- Fail safe application
- Holding force up to 600lbs / 270kgs
- Selectable voltage; 12V or 24V DC
- Lock status monitoring func
- CE certificated

Technical Data

Function	Fail-safe
Current Drain	480 mA @ 12 VDC ; 240 mA @ 24 VDC
Input Voltage	12 - 24 V DC
Holding Force	270 kg
Housing Finishing	Anodized Aluminium Housing
Weight	2 kg
Armatür Size	180x38x11mm
Magnet Size	228x38x27 mm
Operating Temperature	-10 °C to 55 °C

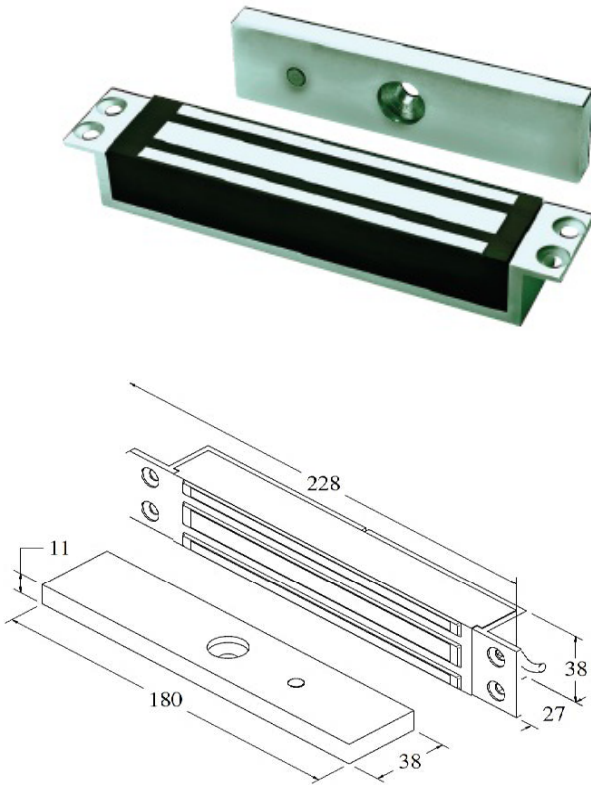

ASSA ABLOY Opening Solutions
 İkitelli Org. San. Bolg. İpkas San. Sit.
 3.Etap C Blok No:15 Basakşehir
 34490 İstanbul /Turkey

Telefon : +90 212 503 41 00
 Faks : +90 212 552 52 55
 E-mail : proje@assaabloy.com

ASSA ABLOY
 Opening Solutions

Experience a safer
 and more open world