

SIROCCO SELF CLOSING SYSTEM

For sliding timber and metal doors. Max. 80kg.

APPLICATION

- Suitable for both domestic and commercial interior applications
- Designed to give a smooth and quiet operation, with a hydraulically controlled soft close feature
- Adjustable closing speed feature
- Door brake to reduce opening speed to prevent damage to the door and system
- Operational between temperature ranges of -10°C to 40°C
- Optional hold open unit giving adjustable time delay before self closing

DOOR SPECIFICATION

Track System	Sirocco
For Individual Doors:	
Max Door Weight	80kg
Min Door Width	800mm
Max Door Width	1200mm
Door Thickness	30-46mm

STANDARD SETS AND PACK

Sets comprises of aluminium track (2200mm), hangers, hydraulic control unit, power spring unit, door stops, guides, roller, all screws and fitting instructions.

Pack No.	Application
HSIRRH	Right Hand Opening
HSIRLH	Left Hand Opening
HDELRH	Delayed Closing Timer – Right Hand
HDELLH	Delayed Closing Timer – Left Hand

HARDWARE SPECIFICATION

Guides	H102SS/94	Timber doors - wall mounted and multiple run guide
	H105SS/94	Timber doors - face mounted guide
	H106SS/94	Timber doors - concealed fixing with SS bearing
Channels	H94X	Aluminium (2000, 3000, 4000 & 6000mm lengths)
	H94	Brass (4000 & 6000mm lengths)
	H94P	Polypropylene (2000, 3000, 4000 & 6000mm lengths)
	H94PSC	Aluminium supporting channel and polypropylene (2000, 3000, 4000 & 6000mm lengths)

Accessories

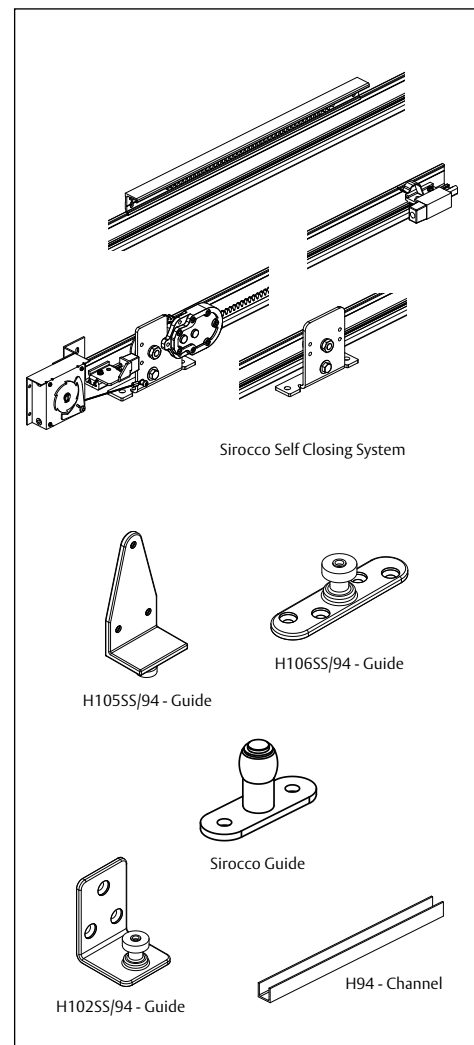

HENDERSON

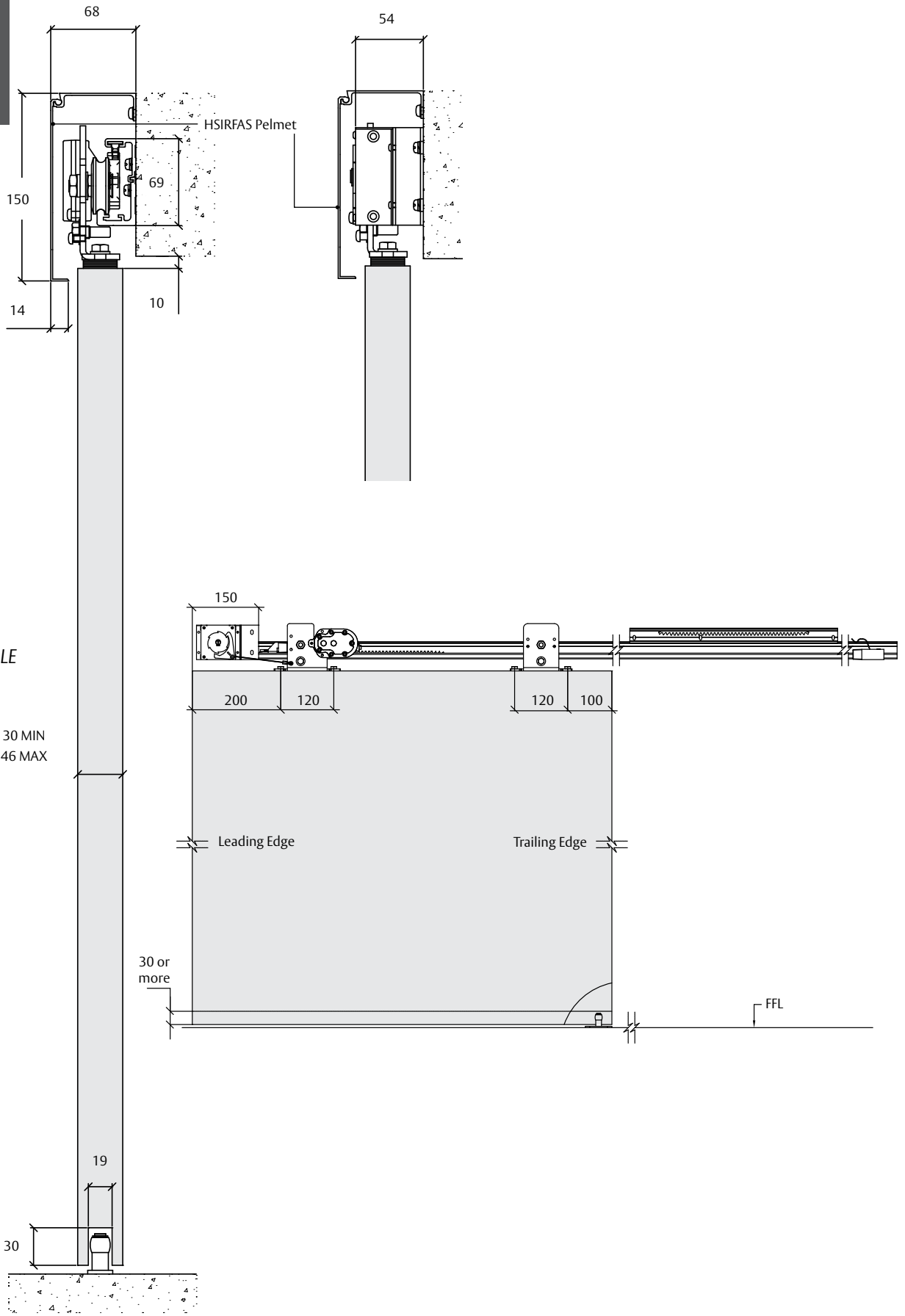

HENDERSON

ISSUE 1-0515

ASSA ABLOY New Zealand Ltd. PO Box 100407, North Shore, Auckland 0745 • 6 Armstrong Road, Albany, Auckland 0632, New Zealand
Within New Zealand: Tel 09 448 9188 Fax 415 7889 www.assaabloy.co.nz • Online Catalogue: www.assaabloycatalogue.co.nz

B100B

The global leader in door opening solutions.

ASSA ABLOY